

## AIR BEARING DICING SPINDLE RANGE

# 11300

TOP SURFACE MOUNTING

CW/CCW ROTATION AVAILABLE

ALTERNATIVE MOUNTING  
ARRANGEMENTS AVAILABLE

WATER COOLING

|                           |                 |
|---------------------------|-----------------|
| Speed Range               | 60,000 rpm      |
| Motor Power Options       | 1.6 kw (2.2 kw) |
| Air Supply Pressure       | 5.5 bar         |
| Bearing Air Consumption   | 80 l/min        |
| Axial Failure Load        | > 160 N         |
| Taper Runout              | ≤ 1 μm          |
| Motor Type                | Brushless DC    |
| Weight (Approx)           | 9 kg            |
| Body Diameter (nominal)   | 80 mm           |
| Vibration with wheelmount | < 0.2 mm/s      |
| Vibration w/o wheelmount  | < 0.1 mm/s      |

- SUPPORTS UP TO A 3" BLADE.
- RANGE OF HUBLESS BLADE HUBS AVAILABLE TO SUIT 40MM BLADE I/D.
- WHEELMOUNT TO SUIT HUBBED BLADES AVAILABLE.
- FLEXIBLE MOTOR TYPE: 1.6 / 2.2 KW, MOTOR SELECTION – ALL IN ONE SPINDLE HOUSING.
- ENHANCED STRUCTURAL RIGIDITY.
- ENHANCED BRUSH LIFE.
- INTEGRAL SHAFT LOCK FOR EASY BLADE REPLACEMENT.

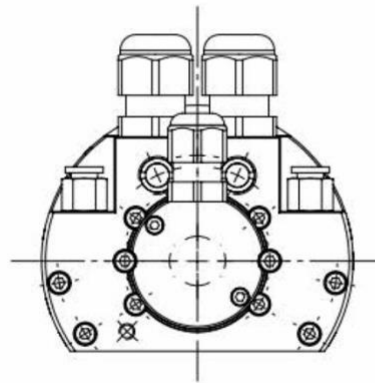

REAR VIEW OF SPINDLE

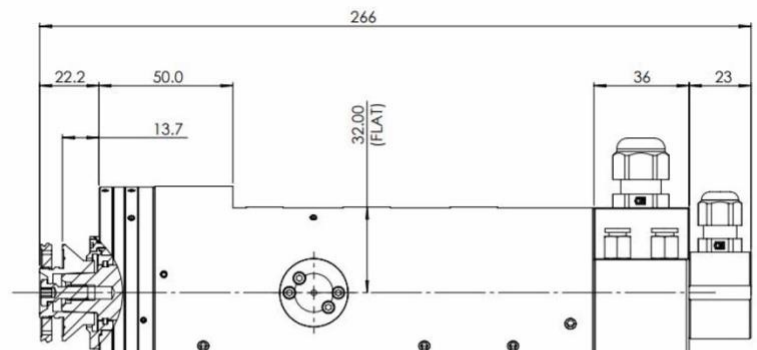

Tel: +44 (0) 1202 894447  
Web: [www.loadpoint.co.uk](http://www.loadpoint.co.uk)